

N & P-Channel 60-V (D-S) MOSFET

Key Features:

- Low $r_{DS(on)}$ trench technology
- Low thermal impedance
- Fast switching speed

Typical Applications:

- White LED boost converters
- Automotive Systems
- Industrial DC/DC Conversion Circuits

PRODUCT SUMMARY		
V_{DS} (V)	$r_{DS(on)}$ (m Ω)	I_D (A)
60	28 @ $V_{GS} = 10V$	35
	35 @ $V_{GS} = 4.5V$	31
-60	80 @ $V_{GS} = -10V$	-20
	105 @ $V_{GS} = -4.5V$	-18



RoHS
COMPLIANT
HALOGEN
FREE

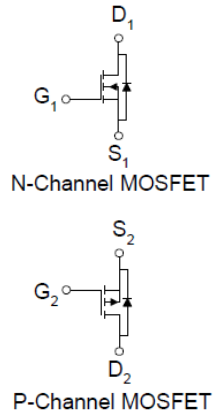
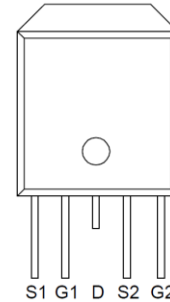

ABSOLUTE MAXIMUM RATINGS (TA = 25°C UNLESS OTHERWISE NOTED)

Parameter	Symbol	Nch Limit	Pch Limit	Units
Drain-Source Voltage	V_{DS}	60	-60	V
Gate-Source Voltage	V_{GS}	± 20	± 20	
Continuous Drain Current ^a	I_D	35	-20	A
Pulsed Drain Current ^b				
Continuous Source Current (Diode Conduction) ^a	I_S	35	-20	A
Power Dissipation ^a	P_D	50	50	W
Operating Junction and Storage Temperature Range	T_J, T_{stg}	T_J, T_{stg}	-55 to 175	°C

THERMAL RESISTANCE RATINGS

Parameter	Symbol	Maximum	Units
Maximum Junction-to-Ambient ^c	$R_{\theta JA}$	50	°C/W
Maximum Junction-to-Case	$R_{\theta JC}$	3	

Notes

- Package Limited
- Pulse width limited by maximum junction temperature
- Surface Mounted on 1" x 1" FR4 Board.

Electrical Characteristics

Parameter	Symbol	Test Conditions	Min	Typ	Max	Unit
Static						
Gate-Source Threshold Voltage	$V_{GS(th)}$	$V_{DS} = V_{GS}, I_D = 250 \mu A$ (Nch)	1			V
		$V_{DS} = V_{GS}, I_D = -250 \mu A$ (Pch)	-1			V
Gate-Body Leakage	I_{GSS}	$V_{DS} = 0 V, V_{GS} = \pm 20 V$			± 100	nA
Zero Gate Voltage Drain Current	I_{DSS}	$V_{DS} = 48 V, V_{GS} = 0 V$ (Nch)			1	μA
		$V_{DS} = -48 V, V_{GS} = 0 V$ (Pch)			-1	
On-State Drain Current ^a	$I_{D(on)}$	$V_{DS} = 5 V, V_{GS} = 10 V$ (Nch)	45			A
		$V_{DS} = -5 V, V_{GS} = -10 V$ (Pch)	-25			A
Drain-Source On-Resistance ^a	$r_{DS(on)}$	$V_{GS} = 10 V, I_D = 20 A$ (Nch)			24	$m\Omega$
		$V_{GS} = 4.5 V, I_D = 16 A$ (Nch)			30	
		$V_{GS} = -10 V, I_D = -10 A$ (Pch)			85	$m\Omega$
		$V_{GS} = -4.5 V, I_D = -8 A$ (Pch)			105	
Forward Transconductance ^a	g_{fs}	$V_{DS} = 15 V, I_D = 20 A$ (Nch)		15		S
		$V_{DS} = -15 V, I_D = -10 A$ (Pch)		11		S
Diode Forward Voltage ^a	V_{SD}	$I_S = 17 A, V_{GS} = 0 V$ (Nch)		0.89		V
		$I_S = -10 A, V_{GS} = 0 V$ (Pch)		-0.98		V
Dynamic ^b						
Total Gate Charge	Q_g	N - Channel $V_{DS} = 30 V, V_{GS} = 4.5 V,$ $I_D = 20 A$		9		nC
Gate-Source Charge	Q_{gs}			3		
Gate-Drain Charge	Q_{gd}			4		
Turn-On Delay Time	$t_{d(on)}$	N - Channel $V_{DS} = 30 V, R_L = 1.5 \Omega,$ $I_D = 20 A,$ $V_{GEN} = 10 V, R_{GEN} = 6 \Omega$		5		ns
Rise Time	t_r			5		
Turn-Off Delay Time	$t_{d(off)}$			27		
Fall Time	t_f			8		
Input Capacitance	C_{iss}	N - Channel $V_{DS} = 15 V, V_{GS} = 0 V, f = 1 Mhz$		1422		pF
Output Capacitance	C_{oss}			84		
Reverse Transfer Capacitance	C_{rss}			79		
Total Gate Charge	Q_g	P - Channel $V_{DS} = -30 V, V_{GS} = 4.5 V,$ $I_D = -10 A$		10		nC
Gate-Source Charge	Q_{gs}			5		
Gate-Drain Charge	Q_{gd}			4		
Turn-On Delay Time	$t_{d(on)}$	P - Channel $V_{DS} = -30 V, R_L = 3 \Omega,$ $I_D = -10 A,$ $V_{GEN} = -10 V, R_{GEN} = 6 \Omega$		5		ns
Rise Time	t_r			4		
Turn-Off Delay Time	$t_{d(off)}$			30		
Fall Time	t_f			11		
Input Capacitance	C_{iss}	P - Channel $V_{DS} = -15 V, V_{GS} = 0 V, f = 1 Mhz$		1143		pF
Output Capacitance	C_{oss}			84		
Reverse Transfer Capacitance	C_{rss}			60		

Typical Electrical Characteristics - N-channel

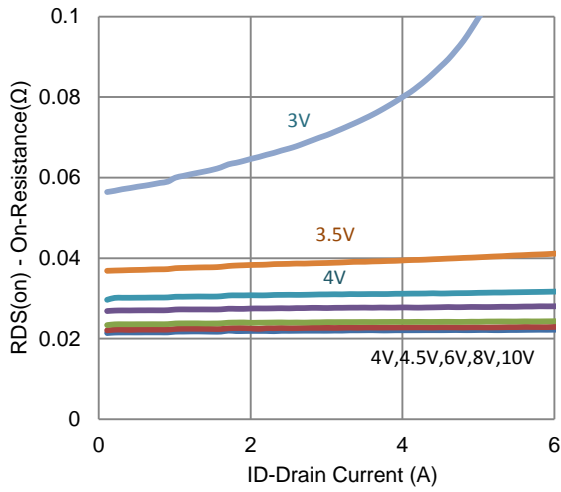

1. On-Resistance vs. Drain Current

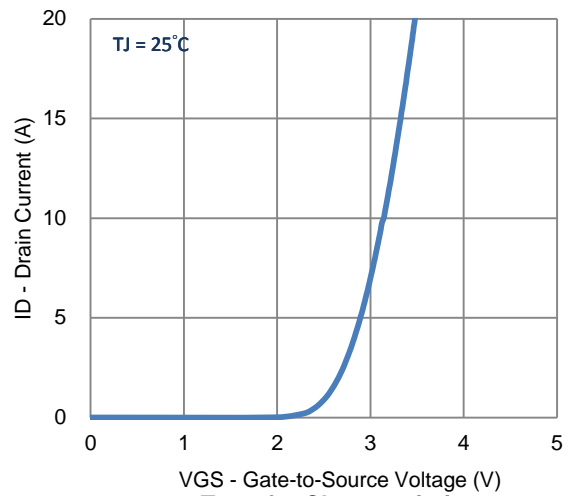

2. Transfer Characteristics

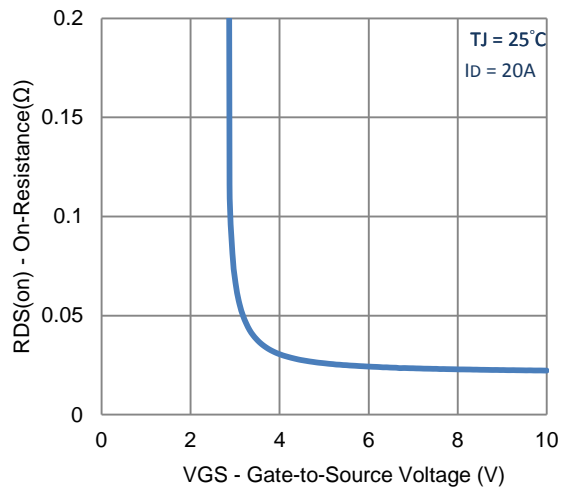

3. On-Resistance vs. Gate-to-Source Voltage

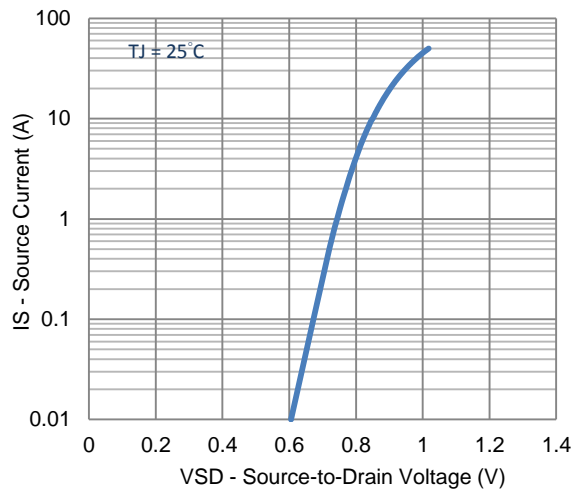

4. Drain-to-Source Forward Voltage

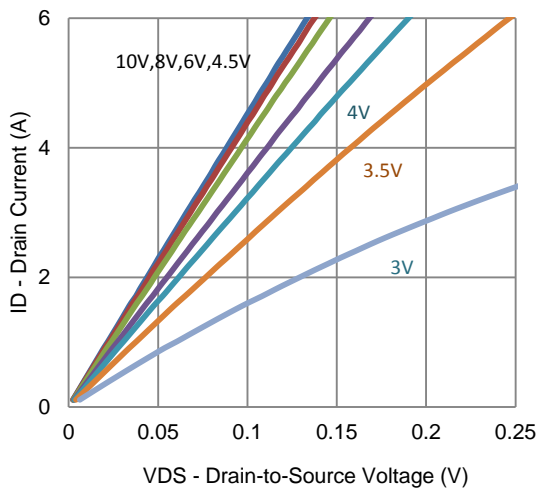

5. Output Characteristics

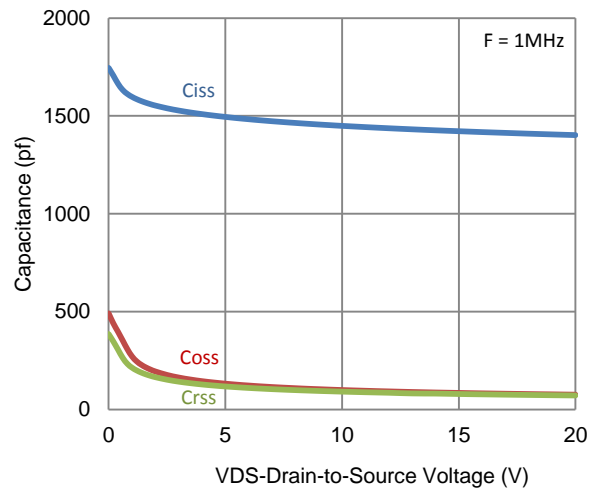

6. Capacitance

Typical Electrical Characteristics - N-channel

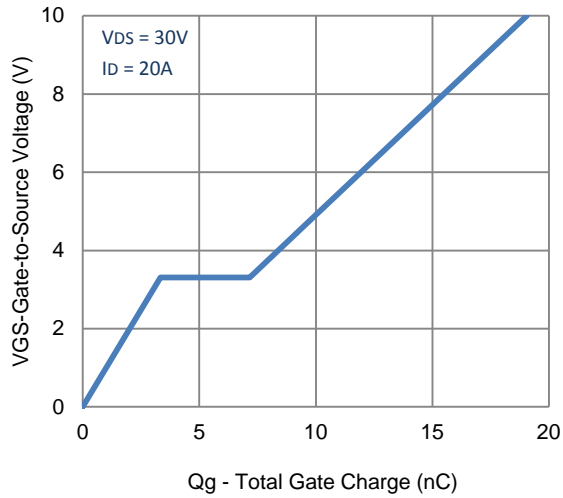

7. Gate Charge

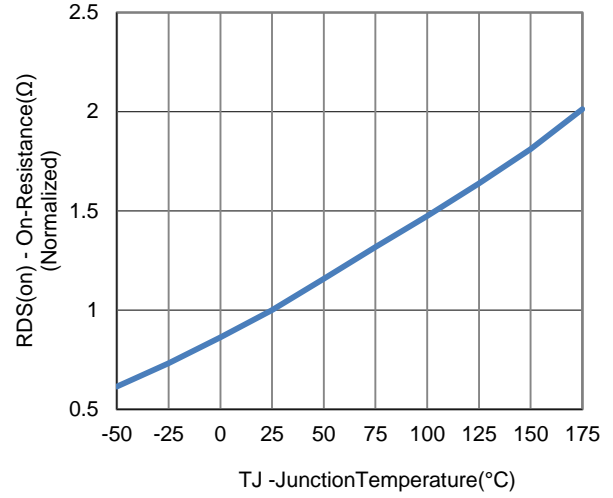

8. Normalized On-Resistance Vs Junction Temperature

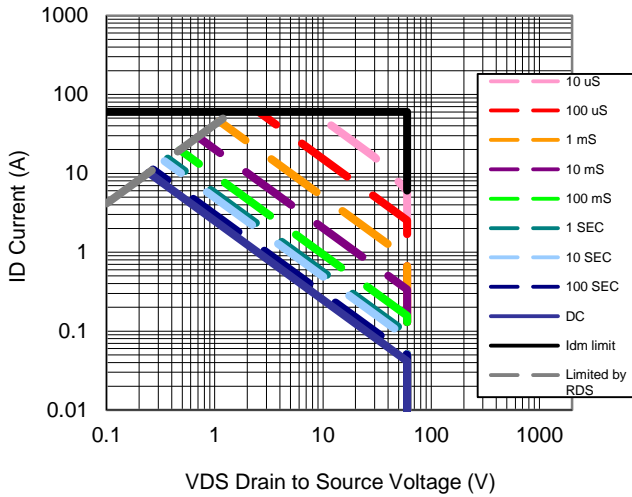

9. Safe Operating Area

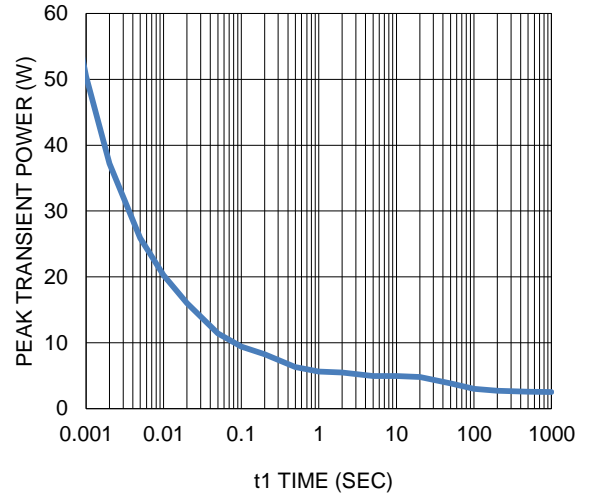

10. Single Pulse Maximum Power Dissipation

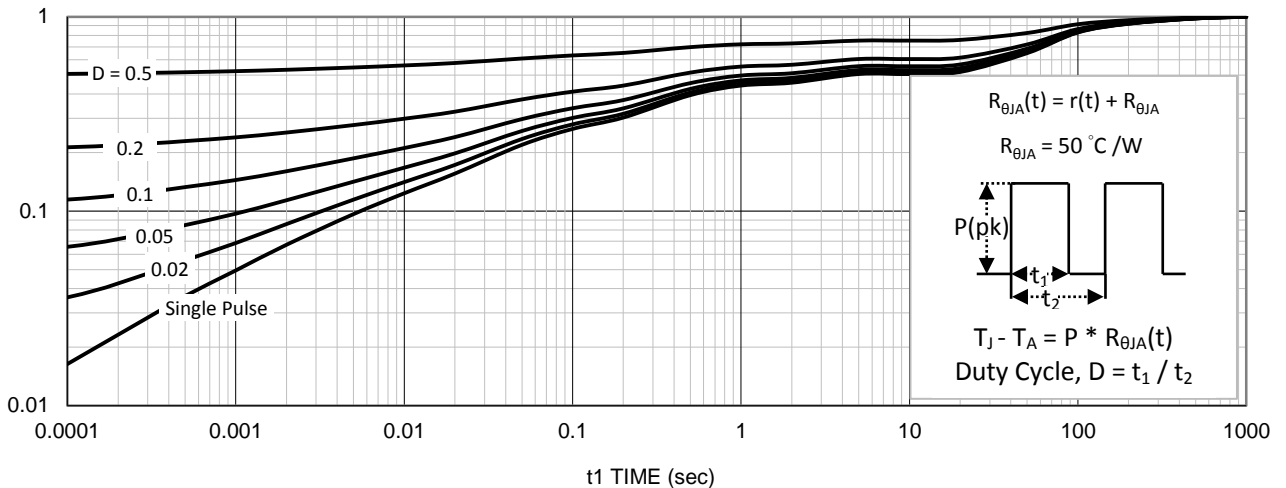

11. Normalized Thermal Transient Junction to Ambient

Typical Electrical Characteristics - P-channel

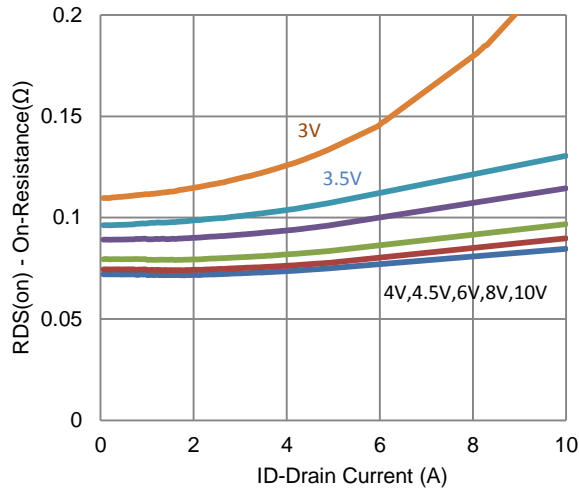

1. On-Resistance vs. Drain Current

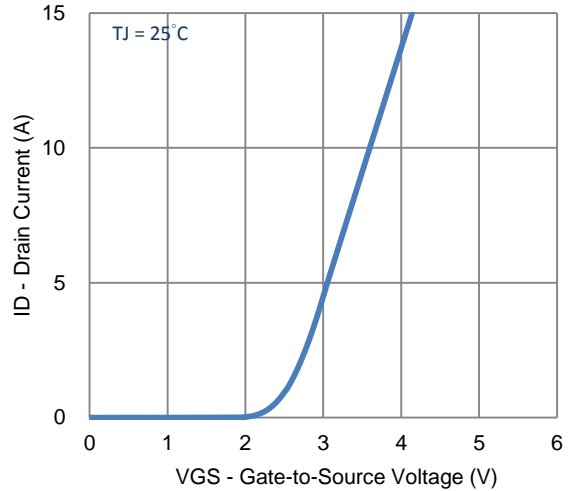

2. Transfer Characteristics

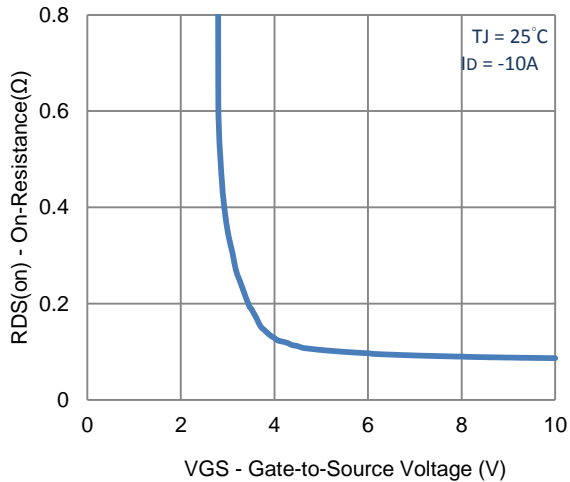

3. On-Resistance vs. Gate-to-Source Voltage

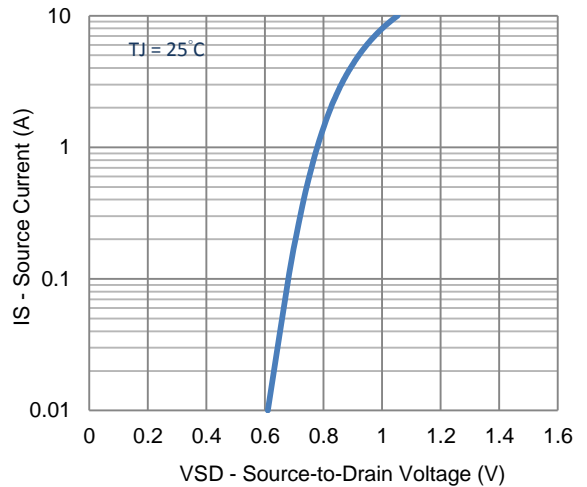

4. Drain-to-Source Forward Voltage

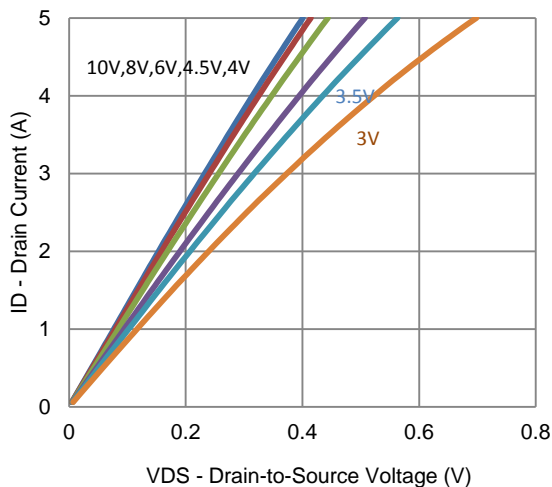

5. Output Characteristics

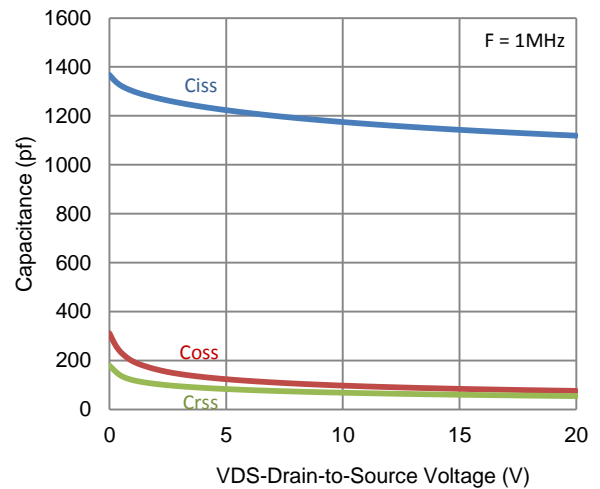

6. Capacitance

Typical Electrical Characteristics - P-channel

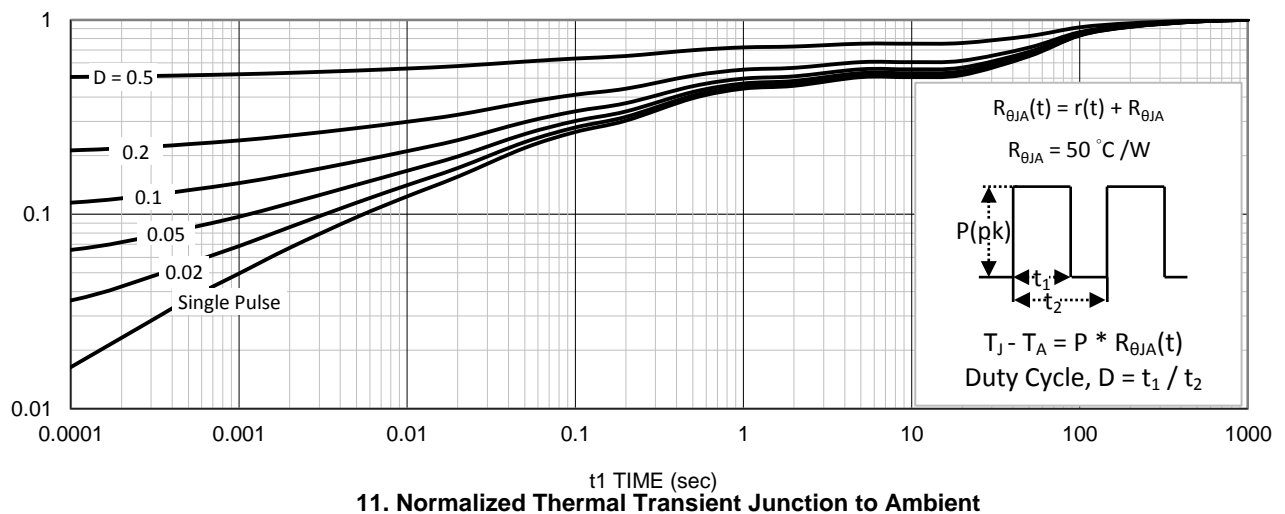
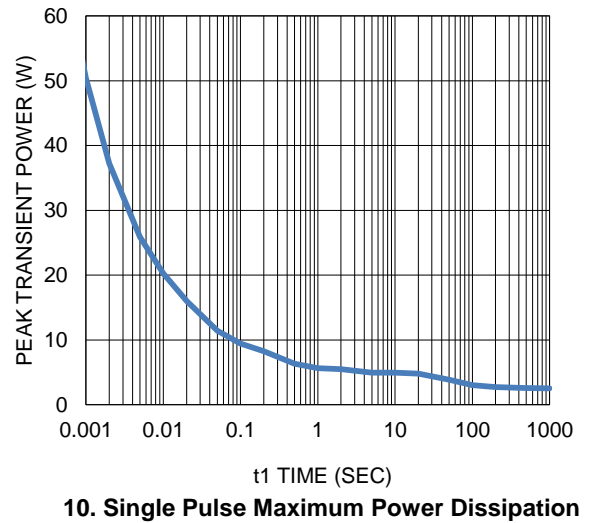
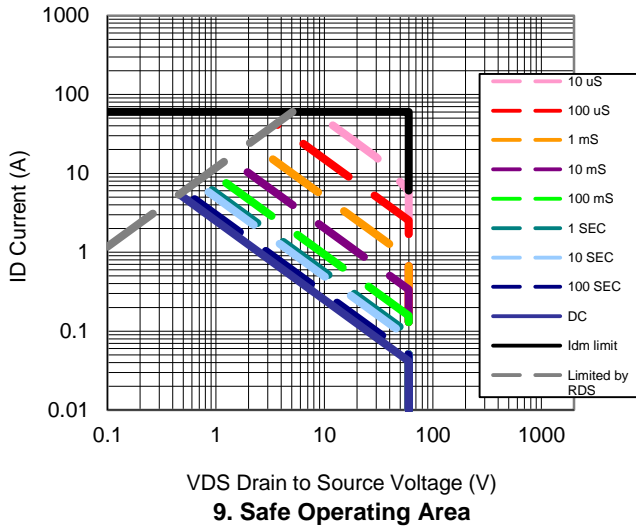
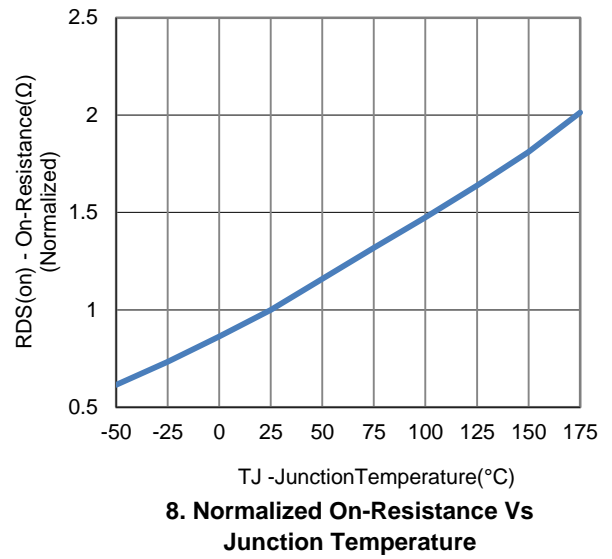
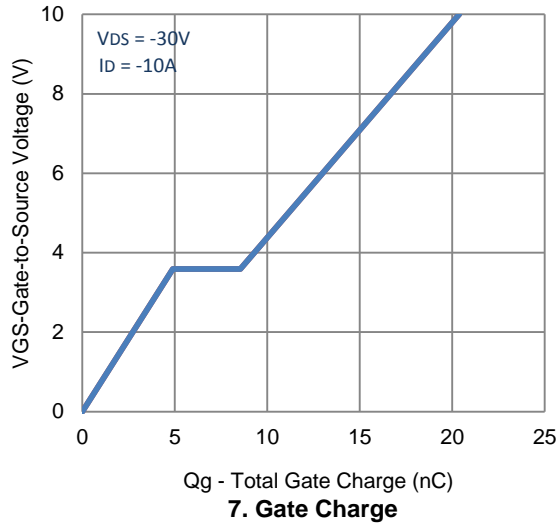

Package Information

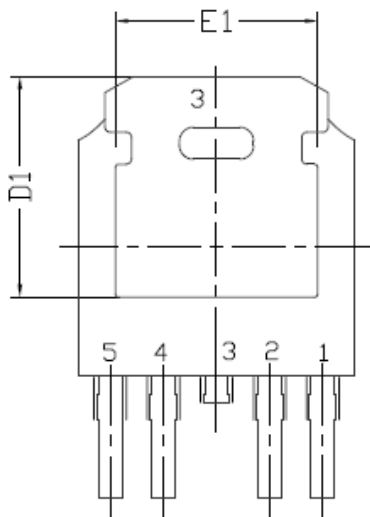
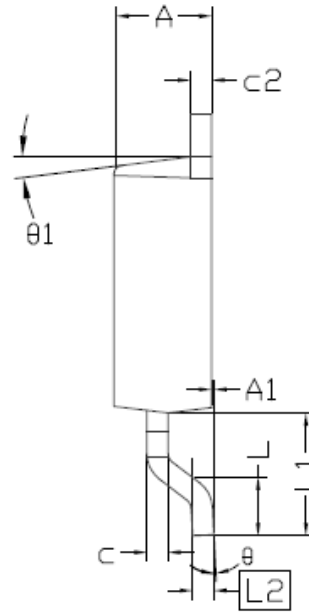
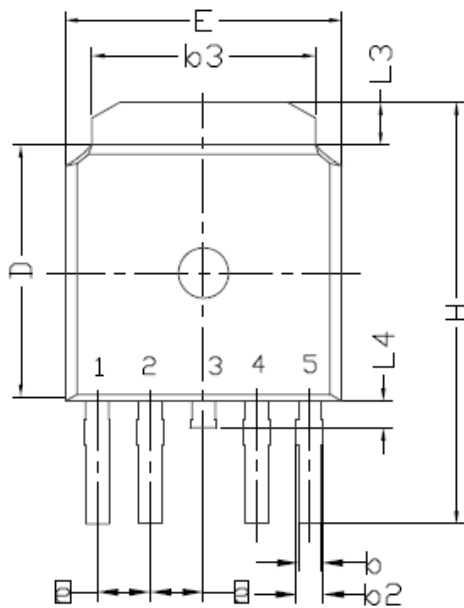

SYMBOL	DIMENSIONAL REQMTS			INCHES REQMTS		
	MIN	NOM	MAX	MIN	NOM	MAX
E	6.35	6.60	6.73	0.250	0.260	0.265
L	1.40	1.52	1.77	0.055	0.060	0.070
L1	2.743 REF			0.108 REF		
L2	0.508 BSC			0.020 BSC		
L3	0.89	1.016	1.27	0.035	0.040	0.050
L4	0.64	--	1.01	0.025	--	0.040
D	6.00	6.10	6.20	0.236	0.240	0.244
H	9.40	10.00	10.40	0.370	0.394	0.409
b	0.508	0.56	0.711	0.020	0.022	0.028
b2	0.584	0.636	0.787	0.023	0.025	0.031
b3	5.21	5.34	5.46	0.205	0.210	0.215
e	1.27 BSC			0.050 BSC		
A	2.20	2.30	2.38	0.087	0.091	0.094
A1	0	--	0.127	0	--	0.005
c	0.457	0.50	0.60	0.018	0.020	0.024
c2	0.457	0.50	0.60	0.018	0.020	0.024
D1	5.21	--	--	0.205	--	--
E1	4.318	--	--	0.170	--	--
theta	0°	--	10°	0°	--	10°
theta1	0°	7°	15°	0°	7°	15°